

Series 600 Chlorine & Sulfur Dioxide Gas Feed Systems

Aquatech has been specializing in the treatment and chlorination of water systems since 1994. A commitment to quality, safety and convenience sets **Aquatech** apart from its competition. Other companies simply say that their products are the best. Some of the reasons why you can feel and see the difference with **Aquatech** are outlined below.

Quality

With **solid machined parts**, designed with **heavy wall thickness**, it is clear to see that **Aquatech** makes the most durable gas chlorination and sulfonation equipment on the market. Many companies cut cost by using injection molded body parts that crack easily. Aquatech parts are precision **machined from only the finest materials** for use with Chlorine & Sulfur Dioxide gases. Materials are selected for maximum chemical resistance, durability, & resistance to cracking.

Safety

Aquatech makes safety the highest concern. Here are three points, which set **Aquatech** apart from the competition:

1. Durable designs and highest quality machined parts maximize safety by avoiding cracks and breakage.
2. At **Aquatech** a skilled technician follows a rigorous testing procedure for each and every vacuum regulator with Chlorine or Sulfur Dioxide gas.
3. Other brands rely upon O-Rings to prevent pressurized gas from leaking into the room while the **Aquatech** vacuum regulators incorporate a unique design making **Aquatech** the only brand to have no such pressurized leak path. (See diagram to right center.)

Convenience

Aquatech makes every effort to maximize the convenience of our customers. This includes both designing our equipment for ease of operation and offering the best customer support. Examples of our commitment in each area are:

Ease of Operation: Each **Aquatech** Vacuum Regulator is supplied with a **twisted cylinder wrench** that allows comfortable operation of both the **cylinder valve** and the **vacuum regulator yoke**.

FAST SERVICE: **Aquatech** maintains a large inventory that allows us to **ship spare parts, components, and complete systems within 24 hours**. Most orders ship the same day.

QUALITY



Rugged machined parts.

SAFETY

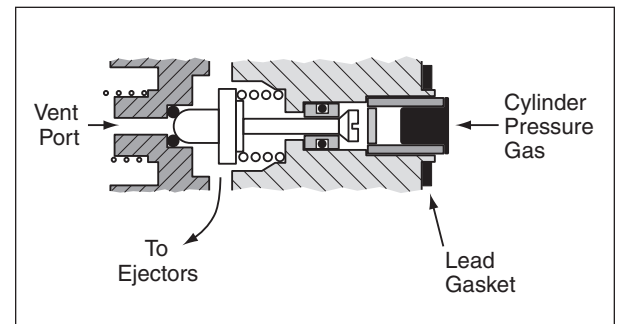

*No pressurized leak path to the room.
Any leak must go to vent.*

CONVENIENCE

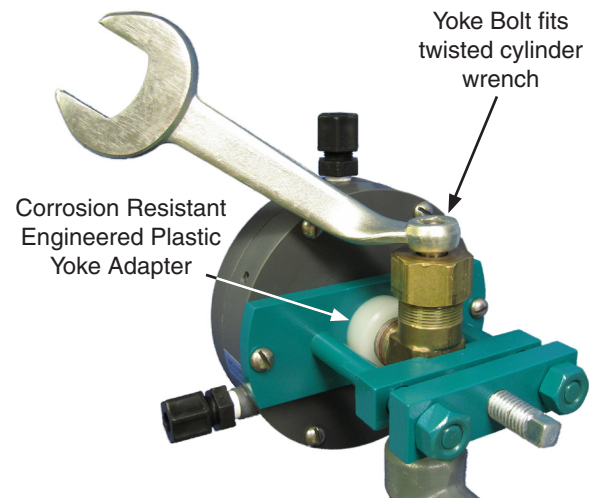

Specifications

Vacuum Regulator

1. Each regulator shall have a spring opposed diaphragm which controls vacuum and closes tight upon loss of vacuum.
2. Each regulator shall incorporate a pressure relief (vent) valve with separate ports for chlorine feed and chlorine vent.
3. Connections shall be provided for tubing vented gas away from the pressure relief (vent) port of each vacuum regulator to atmosphere outside the building. The outside end of the vent tubing shall be equipped with an insect screen.
4. Each regulator shall be equipped with an inlet filter to remove particulate matter from the gas before it enters the inlet safety valve.
5. Flow meter tube and rate valve can optionally be mounted on the vacuum regulator.
6. Each regulator shall include a mechanism to indicate when the cylinder is empty and requires replacement.
7. The design of the regulators shall not rely on any O-ring(s) to prevent pressurized chlorine leaks, into the room, from the region upstream of the inlet safety valve.
8. The vacuum regulator(s) shall mount directly on the gas cylinder valve by means of a corrosion resistant and gasketed yoke assembly complying with the standards of The Chlorine Institute, Inc.

Ejector

1. The ejector(s) shall be the water operated venturi nozzle type. The ejector shall provide the operating vacuum for the chlorination system.
2. The ejector shall incorporate a spring loaded, normally closed check valve to prevent the backflow of water into the chlorine gas equipment. The check valve shall be suitable for back pressures up to a minimum of 145 psi (10 kg/cm²).
3. Ejector check valve shall automatically close upon the loss of vacuum in the Ejector.

Remote Meter

1. A gas flow meter shall be provided to indicate the gas flow rate. The gas flow meter shall be suitable for wall mounting.
2. This gas flow meter shall be equipped with a control valve for manual feed rate adjustment.
3. Flow meter tubes shall indicate flow rates up to _____ and down to a minimum of 1/20 of the maximum value.

Ordering Information

Gas: Chlorine, Sulfur Dioxide

Capacity (maximum feed rate): 1.5, 4, 10, 15, 25, 50 & 100 PPD

Mounting: Direct cylinder or manifold

Number of Feed Points: Specify capacity of each

Example for Up to 100 PPD

673C

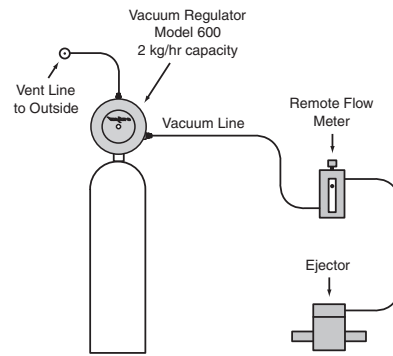

673C-2

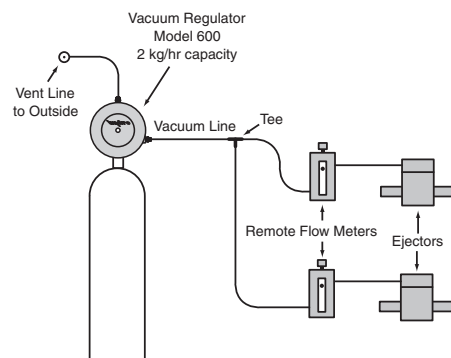

675C

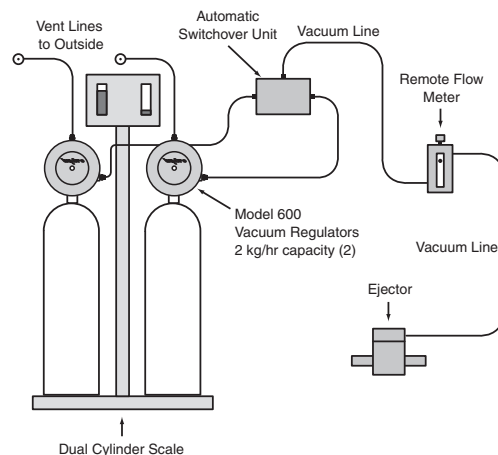

965 34th Street N.W.
Paris, Texas 75460

Ph# (903) 784-3990
Fax# (903) 737-0463
www.aquatechpro.com