

This operating instructions contains safety information that if ignored can endanger life or result in serious injury. They are indicated by this icon.



Use of this pump with radioactive chemicals is forbidden!



Keep the pump protected from sun and water. Avoid water splashes.



OPERATING INSTRUCTIONS MANUAL FOR “WPHRHD”

Read Carefully !



ENGLISH Version

R1-02-08



“WPHRHD” series solenoid dosing pumps comply with the following European regulations:

EN60335-1 : 1995, EN55014, EN50081-1/2, EN50082-1/2, EN6055-2, EN60555,3

Based on directive CEE 73/23 c 93/68 (DBT Low voltage directive) and directive 89/336/CEE (EMC Electromagnetic Compatibility)



GENERAL SAFETY GUIDELINES

Danger! In emergencies the pump should be switched off immediately! Disconnect the power cable from the power supply!

When using pump with aggressive chemicals observe the regulations concerning the transport and storage of aggressive fluids!

When installing always observe national regulations!

Manufacturer is not liable for any unauthorized use or misuse of this product that may cause injury, damage to persons or materials.

Caution! Pump must be accessible at all times for both operating and servicing. Access must not be obstructed in any way!

Feeder should be interlocked with a no-flow protection device.

Pump and accessories must be serviced and repaired by qualified and authorized personnel only!

Always discharge the liquid end before servicing the pump!

Empty and rinse the liquid end before work on a pump which has been used with hazardous or unknown chemicals!

Always read chemical safety datasheet!

Always wear protective clothing when handling hazardous or unknown chemicals!

Some salt generator machine changes the Alcalinity values of the water, please refer to the generator manufacturer for optimal values of Alcalinity for that specific machine.

Introduction:

Metering Pumps “WPHRHD-S” Series are the ideal solution for low / middle dosing of chemicals. All control and setup parameters are available through a digital keyboard and they are displayed on a LCD backlit display. Pump has “Level” input .

Pump's capacity

Flow rate is determined by the stroke speed (frequency) adjustment.

Unpacking

Included into package:

n.2	Dibbles ø6
n.2	Self tapping screws 4,5 x 40
n.1	Delayed fuse 5 X 20
n.2	Foot filter with valve
n.2	Injection valve
n.2	Level probe
m 2x2	Delivery pipe* (opaque PE)
m 2x2	Suction pipe * (transparent PVC)
m 2x2	Discharge pipe (transparent PVC)
n.1	bnc conenction cable
n.1	This installation manual

* If hose is 6x8 there is only a 4meters long hose.
Cut to obtain suction and delivery hoses.

Remove the contents from the box.



**PLEASE DO NOT TRASH PACKAGING.
IT CAN BE USED TO RETURN THE PUMP.**

Pump must be installed in a wall support at a maximum height (**from tank's bottom**) of 1,5 meters.

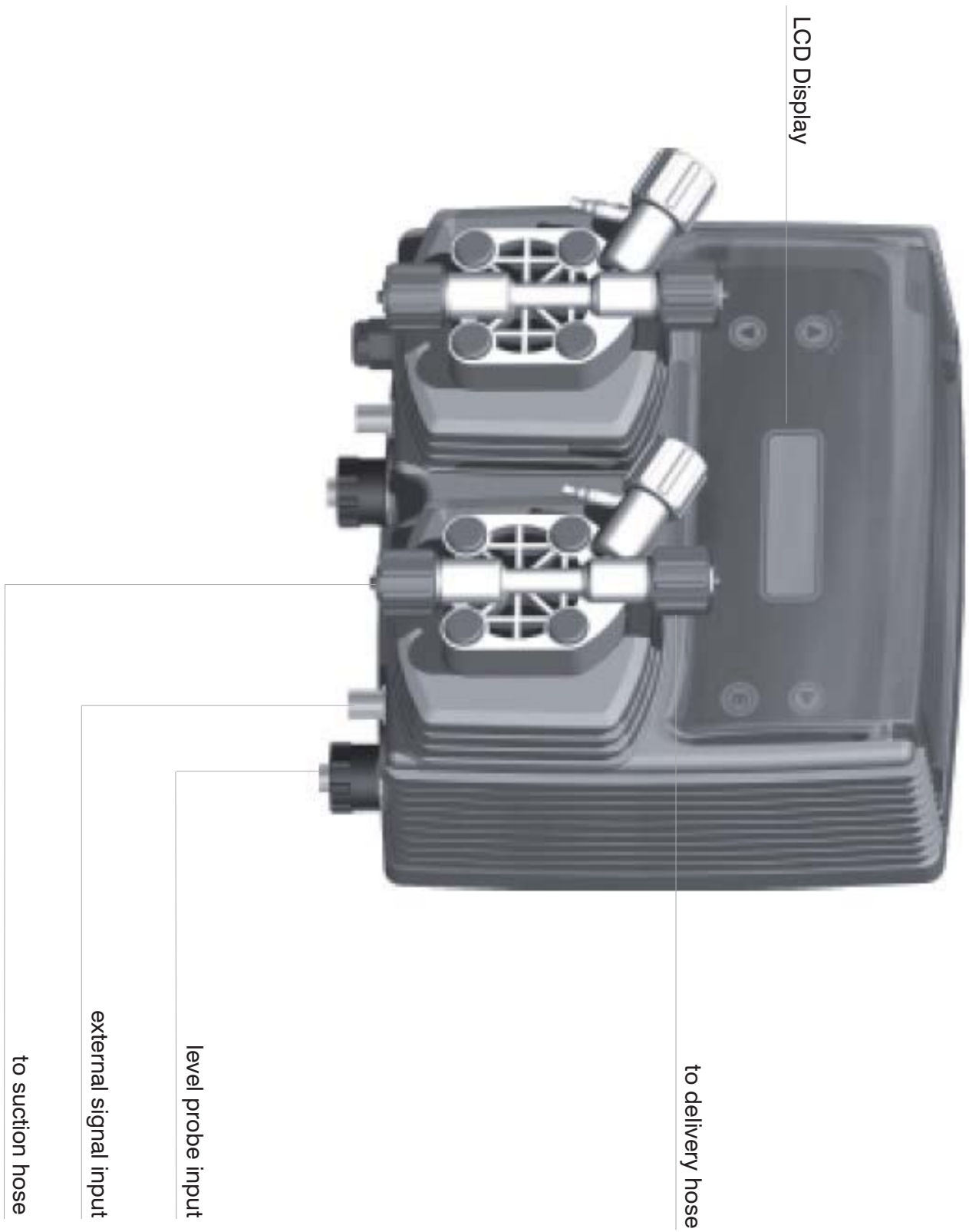

Before to Install warnings

Pump's installation and operativity is made in 4 main steps:

Pump's installation
Hydraulic Installation (hoses, level probe, injection valve)
Electrical Installation (main power connection, priming)
Programming the pump.

Before to start, please read carefully the following safety information.

Protective clothes



Wear always protective clothes as masks, gloves, safety glasses and further security devices during ALL installation procedure and while handling chemicals.

Installation location



Pump must be installed in a safety place and fixed to the table / wall to avoid vibration problems!

Pump must be installed in a easy accessible place!

Pump must be installed in vertical position!

Avoid water splashes and direct sun!

Hoses and Valves



*Suction and delivery hoses must be installed in vertical position!
All hoses connections must be performed using only hands' force!
No tongs required!*

Delivery hose must be firmly fixed to avoid suddenly movements that could damage near objects!

Suction hose must be shorter as possible and installed in vertical position to avoid air bubbles suction!

Use only hoses compatibles with product to dose! See chemical compatibility tabl.

If dosing product is not listed please consult full compatibility table or contact chemical's manufacturer!

Hydraulic connections are:

Suction Hose with level probe and foot filter
Delivery Hose with injection valve
Discharge Hose

Suction Hose.

Completely unscrew tightening nut from pump's head and remove assembling components: *tightening nut, holding ring and pipe holder.*

Assembly as shown in fig. (A). Insert hose into pipe holder until it reaches the bottom.

Lock hose on pump's head by screwing down the tightening nut.
Use only hands to do it!

Connect other side of the hose to the foot filter using the same procedure.

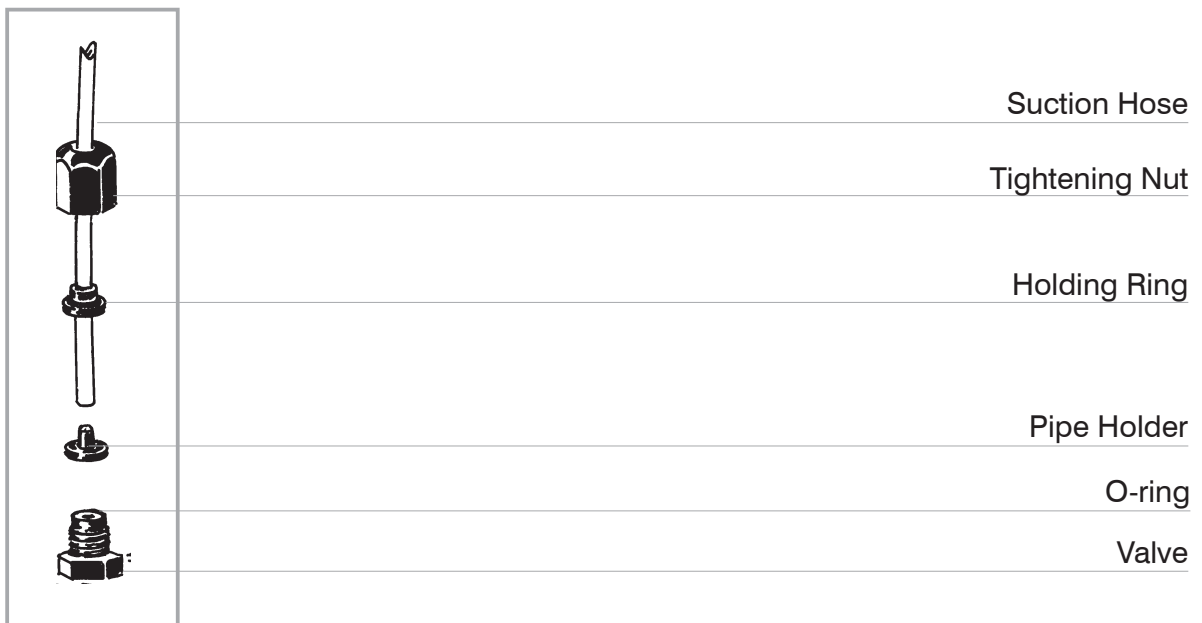
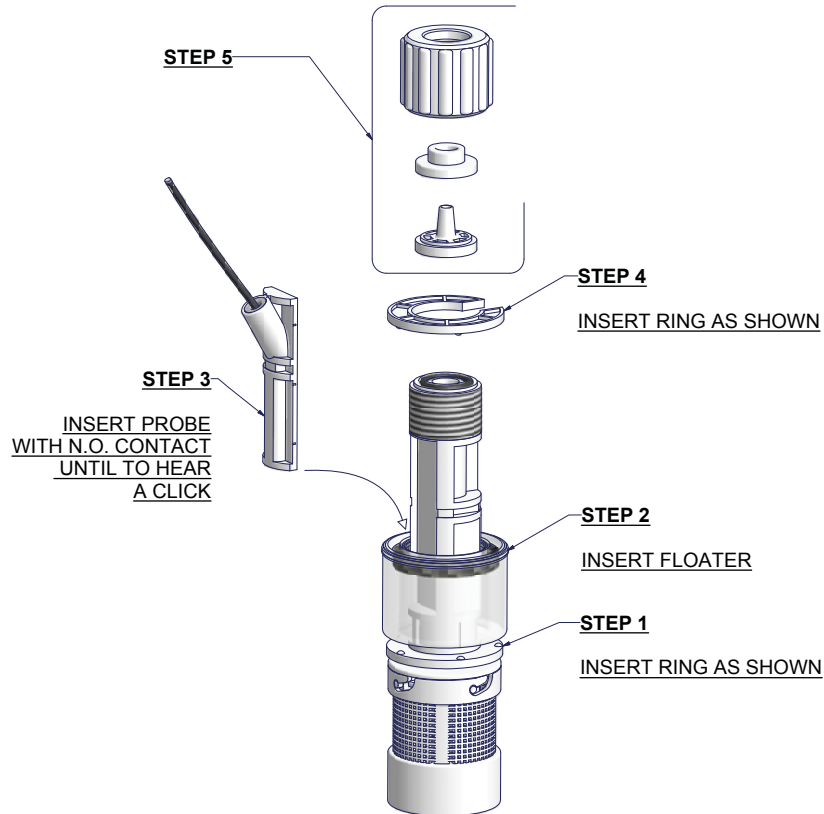

fig. (A)

Hydraulic Installation

Assembling foot filter with level probe.

Level probe must be assembled with foot filter using the provided kit. Foot valve is made to be installed into tank's bottom without sediments priming problem.



Connect BNC from level probe into pump's level input (front side of the pump). Put level probe assembled with foot filter into tank's bottom.

Warning: If there is a mixer installed into tank, install a suction lance instead of level probe / foot filter.

Delivery Hose.

Completely unscrew tightening nut from pump's head and remove assembling components: *tightening nut, holding ring and pipe holder.*

Assembly as shown in fig. (A). Insert hose into pipe holder until it reaches the bottom.

Lock hose on pump's head by screwing down the tightening nut. Use only hands to do it!

Connect other side of the hose to the injection valve using the same procedure.

Discharge hose.

Insert one side of discharge hose into discharge connector as shown in fig (C).

Insert other side of discharge hose into product's tank.

During priming procedure product exceeding will flow into tank.

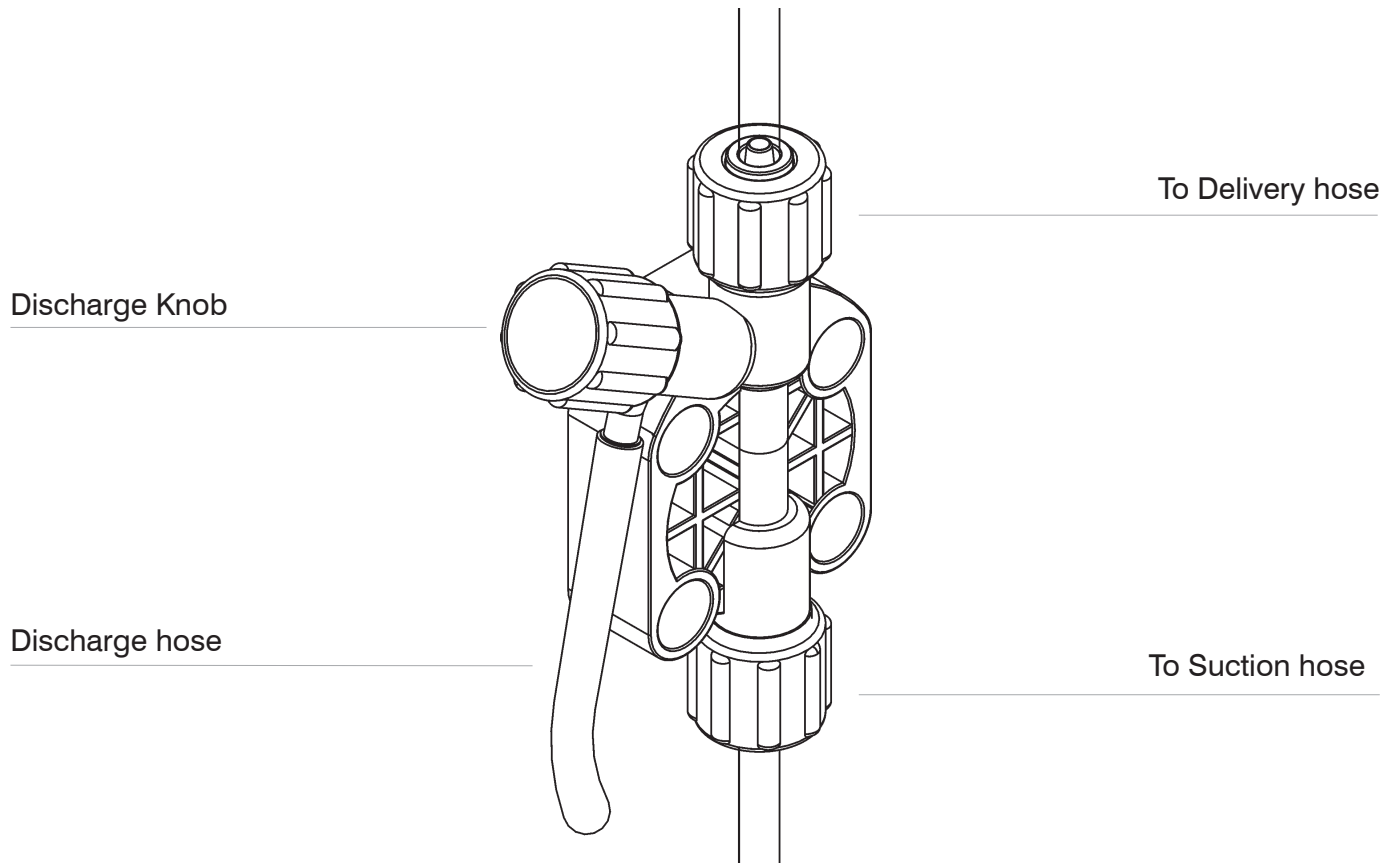
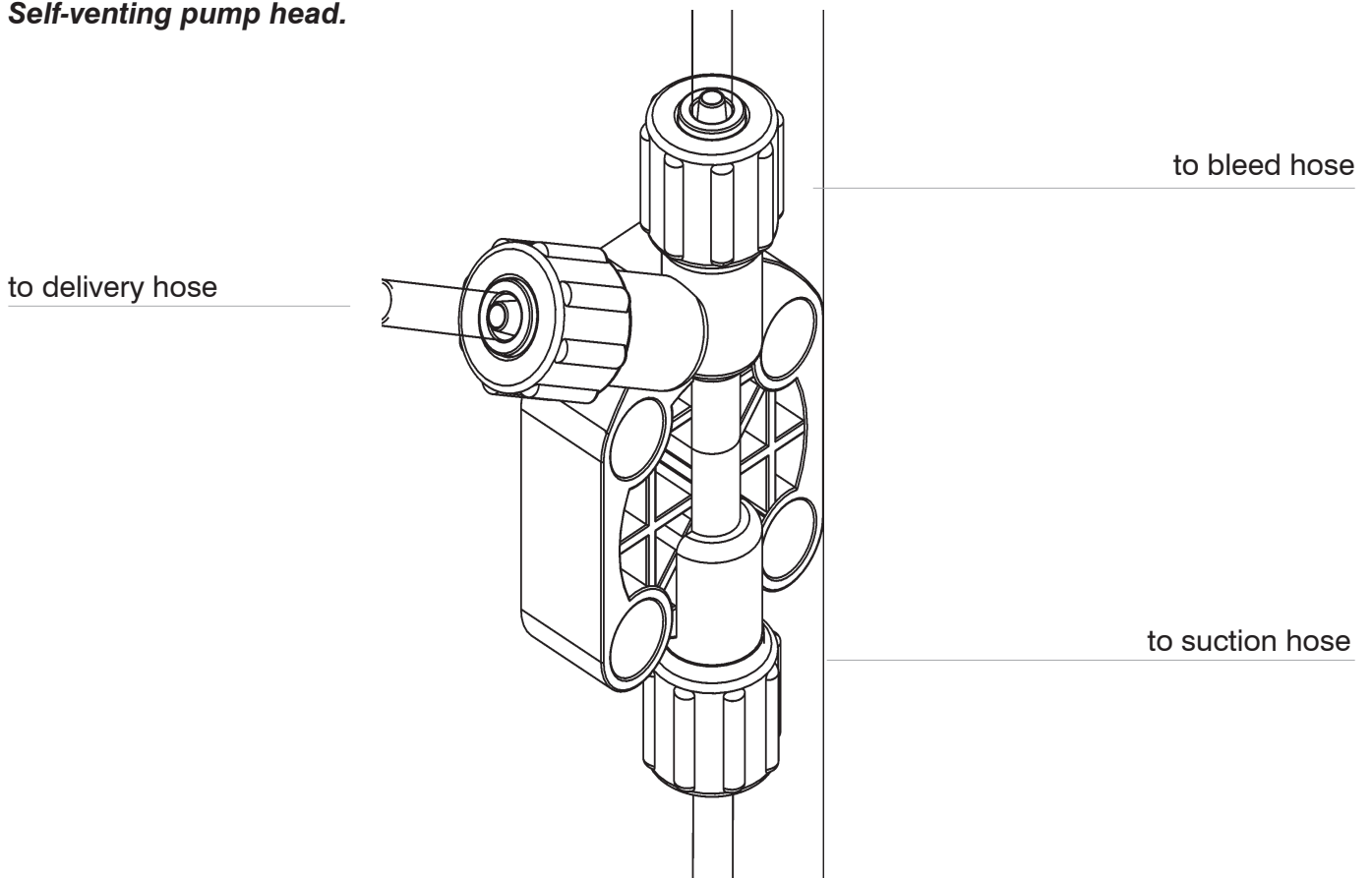

fig (C)

For priming procedure see page 14.

Hydraulic Installation

Self-venting pump head.



Self-venting pump head must be used when using chemicals that produce gas (i.e. hydrogen peroxide, ammonium, sodium hypochlorite at particular conditions).

Hoses assembling procedure (*including purge hose*) is described in fig. (A).

Notes:

- suction, delivery and purge valves are DIFFERENT! Do not exchange them!
- delivery and purge hoses are made of same material!
- it's allowed to lightly bend discharge hose!
- during calibration procedure ("TEST") insert discharge hose into BECKER test-tube!

All electrical connections must be performed by **AUTHORIZED AND QUALIFIED** personnel only. Before to proceed, please, verify the following steps:

- verify that pump's label values are compatible with main power supply.
- pump must be connected to a plant with a differential switch (0,03A sensitivity) if there isn't a good ground.
- to avoid damages to the pump do not install it in parallel with heavy inductance load (for example: engines). A relay switch must be used.

“WPHRHD” SERIES CONNECTIONS

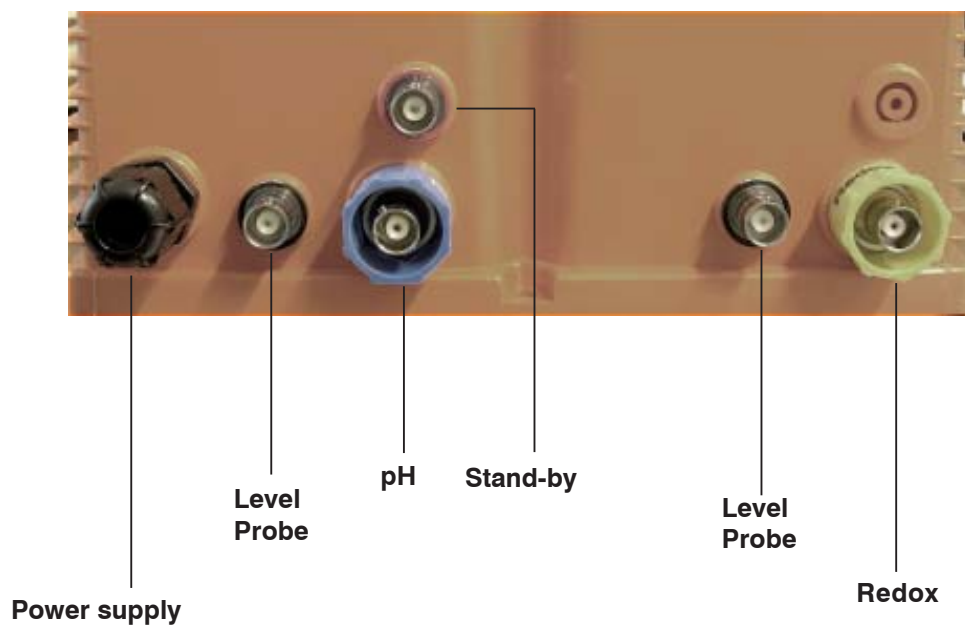

Programming

GENERAL INFORMATION

“WPHRHD-S” are designed for the measurement and metering of acid and chlorine additives in small and medium size swimming pools. The information read by the pumps group is displayed on a backlit liquid crystal display. Data may be entered through a keyboard. All data read by the pumps group are displayed simultaneously. Metering is of proportional type, with the option of regulating both flow-rate for each individual metering head, as well as the proportional range. It is equipped with a low additive supply level alarm, made up of a magnetic float type sensor; when the additive is finished, this device stops the relative metering pump and generates a message which appears on the display. To facilitate pump priming on installation, the two metering pumps can be manually and independently activated by means of specific command buttons. When washing out the pool filters, or when water is not circulating around the electrode holders (PED), metering can be suspended by an external command signal. The pumps group is housed in a plastic case made of “Noryl”; designed to be wall mounted.

RANGE

The pumps group is designed to function with pH levels between 0 and 14.00 pH, with reading definition to 0.01 pH. Voltage in mV may vary between 0 and 1999 mV, with resolution to 1mV. The pumps group can accept a sensitivity range between 46 and 72 mV/pH with offset of ± 70 for the pH probe, while for the mV probe the offset is ± 200 mV.

INPUT SIGNALS

The pumps group has 2 analog inputs for constant monitoring of the following quantities: pH, mV. Each section has low-level controls for the fluid being metered. The STAND BY input deactivates the metering pumps. The metallic components of the level and stand-by connectors are attached to the electrical earth. The input is active with the contact closed.

DISPLAY

When switched on, after a 20sec stand-by, the following image appears on pump’s display:

7.24 pH 650 mV fig.1
00 % 10 %

The two value above represent the water parameters while the lower ones display the quantity that the metering pump is injecting. The value is expressed as a percentage of maximum flow-rate.

PASSWORD

Access to the **SETUP** menu is protected by a password made of four numbers. The pumps group is supplied with a default password: 0 0 0 0. The password may be entered or modified.

PROGRAMMING PASSWORD

Instrument cannot be into “OFF” mode to enter into main menu. Keep pressed “ENTER” key for about three seconds. Display shows:

Enter Password fig. 2
> 0 0 0 0

Default password is “0000”. Press “ENTER”. Display shows:

Setup Menu fig. 3
<Set-Point>

Choose “Parameter” using “UP” and “DOWN” keys, then press “ENTER” key. Display shows:

DELAY:00 MODE1
NEW PW: 0 0 0 0

Press “RIGHT” key twice. Insert the new password using arrows keys. Press “RIGHT” for next digit. Then press “ENTER” to confirm the new password. Display shows:

DATA SAVED fig. 5

Press “ESC” to return to operating mode.

PASSWORD, DELAY AND MODE

From fig. 4 the delay mode can be set. The delay time (0÷60 min) delays the activation of the dosing activity after start up or during stand by mode. Into Mode 1 (standard functioning way) dosing activity of acid and chlorine is simultaneous.

Into Mode 2, dosing activity of chlorine follows pH stabilization. Press ENTER to confirm the data, the display will show for few seconds:

DATA SAVED fig. 5

Press “ESC” to return to operating mode.

SPECIAL FUNCTIONS

OFF

The pumps group doesn't have a power switch, to disable it press the “UP” key for about two seconds. The display will show “OFF”. To return into normal operating mode press again the “UP” for about 2 seconds.

Remove the probe's head from the first buffer solution, wash it into water, dry it and dip it in the second buffer solution at pH 4 (or pH 9). Shake it lightly and leave the probe immersed. During calibration the value could be different from the buffer solution value. Wait for a stable reading. **The aim of the READING value is to obtain a stable reading during calibration.** The measurement value to calibrate is the lower one. Compare the "Cal" value with the information written on buffer solution label and, if necessary, change it using "UP" and "DOWN" keys. Otherwise press ENTER. If the operation has been performed correctly, and the probe is in good condition, probe efficiency will be displayed for a few seconds on display:

SLOPE: 58 mV / pH fig.9
OFFSET: + 010 mV

If calibration procedure has failed the display shows:

SLOPE of pH fig.10
UNCALIBRATED

mV section

Calibration of the mV section can be performed in two ways: the first by alignment with a buffer solution, the second by reading the residual chlorine level of the pool with the DPD1, comparison with the attached graph followed by alignment of the pumps group. The choice of method is exclusively at the user's discretion. In both cases, to establish the set-point value, a check using the DPD1 or other analysis system is necessary. The enclosed graphs provide a reference between the mV value read by the pumps group and the quantity of residual chlorine expressed in mg/litre, and are linked to the pH value

Alignment with buffer solution

Before proceeding, the 650mV buffer solution must be obtained and the yellow probe plug inserted into the relative socket on the pumps group. Remove probe's protective cap and wash probe's head into water, dry it, and put it in the buffer solution at 650 mV. Shake it lightly and leave it into solution. Follow previous instructions to go into "Setup Menu" as shown in fig. 6. Move cursor over "mv Probe" then press ENTER. Display shows:

Reading: 655 mV fig.11
Cal 1 at 650 mV

"Reading" is the direct reading of buffer solution. During calibration the value could be different from the buffer solution value. Wait for a stable reading. **The aim of the READING value is to obtain a stable reading during calibration.** The measurement value to calibrate is the lower one. Compare the "Cal" value with the information written on buffer solution label and, if necessary, change it using "UP" and "DOWN" keys. Otherwise press ENTER.

OFFSET of mV fig.12
Cal. at - 010 mV

If calibration procedure has failed the display shows:

OFFSET of mV fig.13
UNCALIBRATED

Programming

Alignment with DPD1

Install the “WPHRHD - WPHRHS”, insert probes and start the plant. Wait until chlorine value is near the desired level. Proceed with analysis of the free chlorine level by DPD1 into plant and determine the intersection between the measured chlorine value in mg/lit. and the mV value on the pH graph as shown in graph below. Starting from fig.11 press “ENTER”. If the operation has been performed correctly, and the probe is in good condition, probe efficiency is shown for a few seconds on display as shown on fig.12 Otherwise a calibration error is shown.

REDOX - mg FREE CHLORINE - pH GRAPHIC TABLE

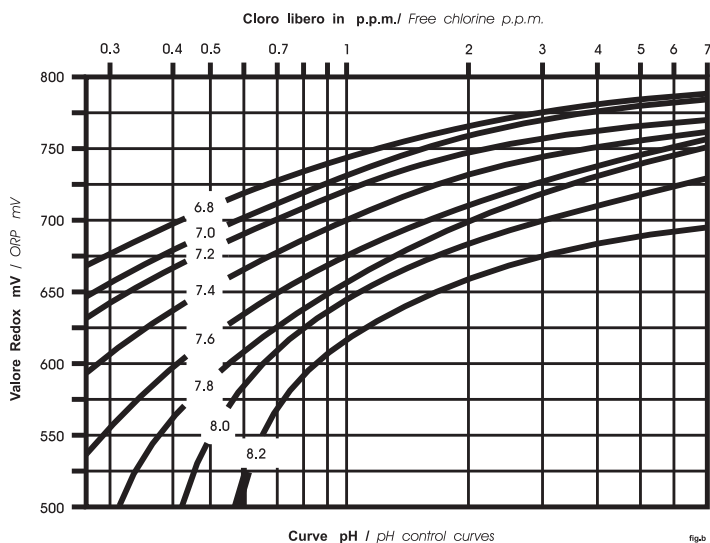

PROGRAMMING SET POINTS

pH section

Enter into setup mode, and from fig. 3 press “ENTER”. The DPHRHD shows:

> Set Point pH < fig.14
Set Point mV

Selected option is “Setpoint pH”. Press “ENTER”. Display shows:

→ 7.3 pH = 00 % fig.15
7.8 pH = 100 %

The cursor indicates the value which may be modified using the “UP” and “DOWN” keys. To shift the cursor to other fields, press the “RIGHT” key. DPHRHD may operate into proportional mode (%) and “ON - OFF” mode.

pH “ON-OFF” working mode

Set the two pH value on ON and OFF. The acid pump will start working at maximum capacity till the pH value read by the probe is 7.3 pH; it will stop when pH value read by the probe will be 7.8 pH.

pH Proportional working mode (%)

Regulate pH values at maximum and minimum % (e.g.: 7.3 pH = 0% and 7.8 pH = 100%).

The pump will start dosing at 7.3 pH; if pH value increases, the pump will increase the capacity proportionally till 100% of the maximum capacity at 7.8 pH.

If pH value should increase, the pump will continue dosing at the set percentage. If the maximum and minimum pH value are more close each other (e.g.: 7.3 and 7.4), the proportional range will be the same, but it will be strictly closed to the ON-OFF functioning mode concept. If the maximum and minimum pH value are the same, the pumps group will work in ON-OFF functioning mode.

When finished press ENTER. The display will confirm data saving by displaying the message SETPOINT SAVED, and returns to the display as in fig.6. To exit press ESC several times.



The pumps group can not works in both functioning mode at the same time, that is with a working value on % and the other on "ON-OFF".

mV section

Enter into setup mode, and from fig. 3 press "ENTER". The DPHRHD shows:

```
> Set Point pH <          fig.14
  Set Point mV
```

Move cursor on "Setpoint mV" by pressing "DOWN" key. Then press ENTER. The display will show:

```
> 600 mV = 100%          fig.15
  650 mV = 0%
```

The cursor indicates the value which may be modified using the "UP" and "DOWN" keys. To shift the cursor to other fields, press the "RIGHT" key. "DPHRHD - DPHRHS" may operate into proportional mode (%) and "ON - OFF" mode.

The pumps group mod. "WPHRHS" (with acid section only) has got a proportional output (230Vac, max 2A or 115Vac, max 2A) for dosing chorine tablets by dissolutor. Intervention time is 100 seconds.

Example: set "WPHRHS" with following parameters:

```
→ 600 mV = 50%
   650 mV = 0%
```

It works if ...
 read value ≤ 600 mV
 read value = 625 mV
 read value ≥ 650 mV

It works if ...
 50 seconds on - 50 seconds off
 25 seconds on - 75 seconds off
 instrument off

The output can be activated as on ON/OFF output (e.g.: for controlling a chlorine generator through hydrolysis technique).

mV "ON-OFF" working mode

Set the two mV value on ON and OFF. The acid pump will start working at maximum capacity till the mV

Programming

value read by the probe is 600 mV; it will stop when mV value read by the probe will be 650 mV.

mV Proportional working mode (%)

Regulate mV values at maximum and minimum % (e.g.: 600 mV = 100% and 650 mV = 0%).

The pump will start dosing at 600 mV; if mV value increases, the pump will increase the capacity proportionally till 100% of the maximum capacity at 650 mV.

If mV value should increase, the pump will continue dosing at the set percentage. If the maximum and minimum mV value are more close each other (e.g.: 600 and 610), the proportional range will be the same, but it will be strictly closed to the ON-OFF functioning mode concept. If the maximum and minimum mV value are the same, the pumps group will work in ON-OFF functioning mode.



The pumps group can not works in both functioning mode at the same time, that is with a working value on % and the other on "ON-OFF".

LEVEL ALARM

"DPHRHD" pumps group are provided of two liquid level alarm (chlorine and acid). The level alarm shows on the display: LOW LEVEL.

The level probe is connected to the right BNC plug on pump's bottom panel. The level probe is made of a N.O. reed contact (10VA, 0,5A max., 220Vac max.), closed by a floating magnet housed in a (PP) plastic box. When the product level goes below the minimum the magnet closes the reed contact.

MAXIMUM TIME DOSING ALARM

This alarm avoid the instrument to go on with dosing procedure after a set time. To setup this alarm enter into instrument's setup as shown on fig.3. Using "UP" or "DOWN" keys move cursor until the display shows the "DOSING ALARM" option. Then press "ENTER". Display shows:

mV: > OFF STP
pH OFF DOS

Move cursor using the "RIGHT" key. To setup the time use "UP" and "DOWN" keys. Time can be set between 1 to 100 minutes or "OFF" to disable it. The setup options are "STP" and "DOS". The "STP" option set the DPHRHD to stop the dosing activity if set time is reached. "DOS" option set the DPHRHD to show an alarm message when set time is reached. Using this option the DPHRHD will NOT stop the dosing procedure.

INSTALLATION

The pump is supplied with all the components needed for installation. To commission the pump, first mount it on any vertical surface or wall using the 6mm dibbles and screws provided with the unit. Avoid to install the pump above containers filled with chemical products that could generate aggressive vapours that may damage the equipment.

Join the two filters/foot valves to the two level probe using the plastic bracket provided with the unit. Distance from the pump head and filter should be about 1,5 m. Connect both ends of foot valves to PVC suction hoses (6x4, flexible, transparent) to pump head suction nipples: make sure that suction valve seal o-ring is in place. Fasten tight the hoses with tube nuts, using only hands. Place filter at short distance (few cm) from tank bottom to avoid solid particles entering the foot valves causing clogging. Keep suction hoses vertical cutting it as short as possible, to avoid generating air bubbles.

Install the two injection valves using only one connection nipple, mounted ahead of the pool water

inlet. Connect both ends of PE discharge hoses (6x4, semi-flexible, opaque) to pump head discharge nipples. Fasten tight the hoses with tube nuts, using hands: a special wrench can be used to tight the hose bearing in mind that fitting are made of plastic consequently easy to break.



Ensure that no object or surface comes in contact with the discharge hose thus avoiding breaking.

When pumping Nitric acid or Solphuric acid with high concentration, we recommend to use PVDF or PTFE hoses or pipes!

The injection valve should always be positioned higher than the additive tank to avoid, in case of injection valve breaking, the liquid gets into the system freely due to syphoning: when the installation is lower than tank, although the injection valve is also a “No-return valve”, it is always recommended to use manufacturer Anty-syphon valve to prevent siphoning or vacuum. Verify ball check valves and injection valves conditions on regular basis, replace if necessary. Do not place top open tanks beneath the pump to avoid damages generated by aggressive chemical vapours.

PRIMING



Carefully read and understand the safety data sheet and all the information about the chemical product to be dosed before start up. Take all the precautions to avoid personal injuries.

To prime the pump without touching chemicals please do as follow:

- connect all hoses into proper places (delivery hose, suction hose, outgassing hose).
- open outgassing valve and turn on the pump.
- unplug power supply
- follows priming procedure as described on pages 5 and 6.

All air inside the pump head will exit through the outgassing outlet. When product will leak from it, close immediately the outgassing valve. If dosing product is particularly dense, to facilitate the priming, insert on vent pipe a syringe of 20 cc and suck inside. If significant quantities of solid state solute are present, the solution must be agitated with the help of a MIX type slow agitator. Connect the supplied 6x4 transparent PVC pipe to the pump vent and insert the other end into the product container, such that the product flows directly into its container as soon as the vent tap is opened to facilitate priming. Be sure to set up the two additives to be metered as indicated on the front panel of the metering pumps group: left pump ACID, right pump CHLORINE, DISINFECTANT. Open the vent tap mounted on the front panel of the pump body until filling the head with the product to be metered. Check that there are no air bubbles present in the delivery pipe.

METERING

All dosing information are calculated by dosing water at 20 °C temperature, at the maximum counterpressure reported on the label, using the injection valve and the % knob set to maximum. Dosing accuracy is $\pm 2\%$ l/h at constant maximum counterpressure and 1 cps flow (**max viscosity: 40 cps**). **Caution: injection capacity is a constant value but a variation in counterpressure or product's viscosity may cause some changes. For further details see “delivery curves” paragraph.**

Programming

TOTAL ALKALINITY

A close cousin of pH, the level of alkalinity in the water is a measurement of all carbonates, bicarbonates, hydroxides, and other alkaline substances found in the pool water. pH is alkaline dependent; that is, alkalinity is defined as the ability of the water to resist changes in pH. Also known as the buffering capacity of the water, alkalinity keeps the pH from “bouncing” all over the place. A very important component of water balance, alkalinity should be maintained in the 80-120ppm range for “gunite” and concrete pools and 125-170ppm for painted, vinyl, and fiberglass pools. Levels should be tested weekly.

ELECTRICAL CONNECTIONS

Pump has to be connected to power supply using the standard ”SCHUKO” plug supplied or the special power supply cable. **Before starting any electrical connection perform the following operations:**

- ensure a correct ground installation!
- if there is a bad ground, install a differential switch with high sensibility (0,03 A) as additional protection from electric shocks!
- check that pump voltage corresponds to supply voltage!
- make ground connection before any other connection!

REPAIR MUST BE PERFORMED BY AUTHORIZED PERSONNEL ONLY.

All electrical connections are made by means of watertight bayonet connectors (BNC) for rapid and safe installation, located on the underside of the pumps group. To start the pumps group, proceed as follows: Connect the pumps group to the mains electricity supply (230Vac \pm 10% or 115Vac \pm 10%), using the plug supplied, and check that the mains earth circuit is up to standard by testing its efficiency. To avoid possible damage to the pumps group caused by extra voltage, never connect it directly in parallel with the swimming pool pump, but use a relay or contactor.

Insert the light blue pH (EPHM) and yellow mV (ERHM) sensors into the relative sockets on the pumps group (pH to the left and mV to the right). The product level and stand-by inputs are low voltage with the metallic contact connected to earth. Finally, connect the level probes to the relative BNC connectors. The «STAND-BY» connector can be used to cut out product metering. The pumps group indicates stand-by status on the display. This input is particularly useful during pool filter back-washing operations, or for pauses in pump operation. Simply close the contact to activate it.

“PED” Installation

For easy and rapid maintenance it is recommended to use the PED type strim-out electrode holder who renders probe maintenance easy while giving accurate pH and mV parameter readings. To install, proceed as follows:

- 1) Position the PED on a vertical support or wall.
- 2) Withdraw the water to treat from the delivery side of the swimming pool re-circulation pump. This ensures accurate sampling of the real pH and mV values present in the pool.
- 3) At the sampling point, install the valve supplied with the pumps group and adjust the flow of water to the electrode to approximately 30 litres/hour.
- 4) Connect the output from the electrode to the drain or recover the water by returning it to the re-circulation plant immediately downstream of the filter, making use of the filter pressure difference. Use of the 4x6 mm pipe is recommended in this case.

We suggest to install a 100micron filter.

ELECTRICAL PROTECTION

Internal circuitry is protected against noises using the EMC system and with a fuse located under the front cover of pump. To replace the fuse (**trained personnel only**) do as follow:

- ***unplug power supply***
- ***remove the 4 screws on the front cover of the pump***
- ***replace fuse, use only approved fuses***
- ***put back cover in place, take care of seal displacement***

MAINTENANCE

The operations shown below should only be carried out by qualified personnel. The Manufacturer does NOT accept liability for any damage caused to people or things deriving from the lack of experience of the operator who performs these operations.

Before proceeding with maintenance and servicing the pump:

- ***wear recommended protection glasses, gloves, etc (see safety data sheet);***
- ***unplug power supply;***
- ***empty discharge hose and vent it to ATM pressure;***
- ***empty suction hose and vent it to ATM pressure.***

Remove pump unscrewing it from the wall or pump holding support and turn pump upside-down to let out all left product inside the pump head. Rinse pump head with clean tap water. In the event pump shall be shipped for repairs, connect suction and discharge valve using a piece of hose.

When entering in contact with the liquid, follow safety data sheet provided by chemical product Manufacturer.

“xPHRHD - xPHRHS” pumps groups need almost no maintenance except for cleaning once a year ball check valves and foot valve/filter. When dosing chemicals with high crystallizing coefficient, perform maintenance periodically (about once a month) and in case the pump has not operated for long time, wash out ball check valves, foot valve/filter and pump head. To remove crystals sediments:

- unscrew injection valve connection and dip discharge hose and foot valve into water
- prime the pump with water and let pump work for five minute
- replace water with crystal solvent product and let pump work for ten minute
- repeat operation again with water for five minute
- install back in place injection valve connection and prime the pump

It's important to tight well and safely the hose couplingnut to avoid chemical leakage damaging the pump. In case of leakage, tight well couplingnut and rinse the pump casing with fresh water.

ELECTRODES CLEANIG AND STORAGE (pH, Redox - mV)

For the pumps group to operate correctly, the electrodes must be periodically cleaned, at least once a month, in HCl for at least 5 minutes, then washed with water. The electrodes must always be kept wet. The flaon containing the protective liquid in which the electrode is immersed is an ideal container for long term storage. Do not remove it before the electrode is due for installation. If the flaon with the liquid is lost, simply immerse the probe in a buffer solution with pH 4, with the addition of 1/100 of saturated KCl. Mains water is sufficient for short term storage.

Do not use distilled water. The electrodes are not covered by the guarantee.

Programming

Fuse or main board replacement is allowed to qualified personnel only. Before to operate disconnect the pump from main power and all hydraulic connections.

For fuse replacement is necessary to use a 3x16 and 3x15 screwdriver and a new fuse (same model of old one).

For main board replacement is necessary to use a 3x16 and 3x15 screwdriver and a new main board (same model of old one).

Fuse replacement procedure:

- Remove 6 screws from pump's back.
- Pull pump's back cover until it's completed separated from pump's front.
- Locate the blown fuse and replace it.
- Reassemble the pump.
- Reinsert screws.

Main board replacement procedure:

- Remove 6 screws from pump's back.
- Pull pump's back cover until it's completed separated from pump's front.
- Remove board's screws.
- Completely disconnect wires from main board and replace it. Reinsert screws.
- Reconnect wires to the main board (see enclosed picture).
- Reassemble the pump.
- Reinsert screws.

During normal operating mode, pump must be checked once for month. Wear needed safety devices and check hoses and all hydraulic components for:

- product leak
- broken hoses
- corroded connections

All maintenance operations must be performed by authorized and trained personnel only. If pump needs factory assistance please use original package to return it.

Before to do it, please, remove all dosing product inside the pump and hoses.

Use only original spare parts!

B Appendix. Construction Materials and Technical info

TECHNICAL FEATURES

Power supply:	230 VAC (190 ÷ 265 VAC)
Power supply:	115 VAC (90 ÷ 135 VAC)
Power supply:	24 VAC (20 ÷ 32 VAC)
Power supply:	12 VDC (10 ÷ 16 VDC)
Pump Strokes:	0 ÷ 180
Suction Height:	1,5 metres
Environment Temperature:	0 ÷ 45°C (32 ÷ 113°F)
Chemical Temperature:	0 ÷ 50°C (32 ÷ 122°F)
Installation Class:	II
Pollution Level:	2
Audible Noise (single head):	74dbA
Packaging and Transporting Temperature:	-10 ÷ 50°C (14 ÷ 122°F)
Protection degree:	IP 65

MANUFACTURING MATERIALS

Case:	Noryl
Pump head:	PVDF
Diaphragm:	PTFE
Balls:	CERAMIC, GLASS, PTFE, SS *
Suction Pipe	PVC
Delivery Pipe:	PE
O-ring:	FP, EP, WAX, SI, PTFE *
Injection connector	PP, PVDF (ceramic, HASTELLOY C276 spring)
Level Probe:	PP, PVDF *
Level probe cable:	PE
Foot Filter:	PP, PVDF *

* as ordered.

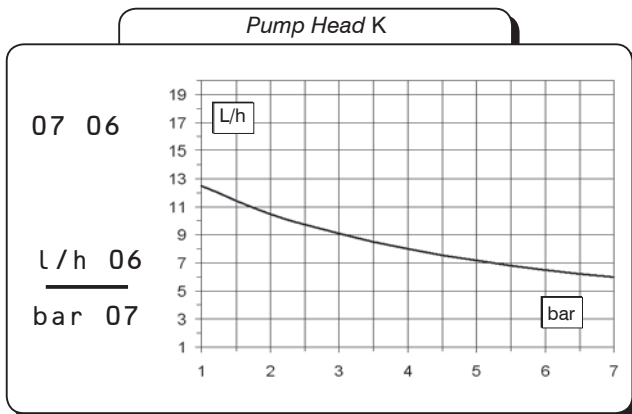

Flow rate indicated is for H₂O at 20°C at the rated pressure.

Dosing accuracy ± 2% at constant pressure ± 0,5 bar.

D Appendix. Dimensions

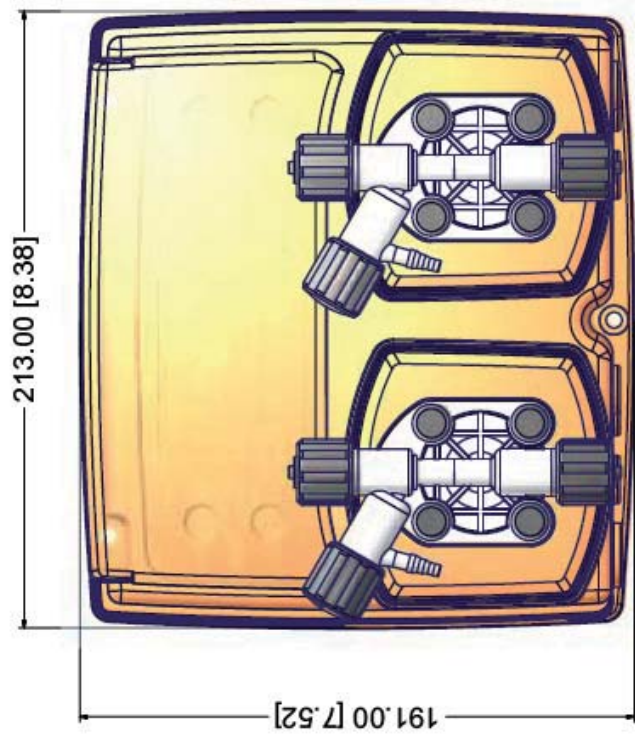
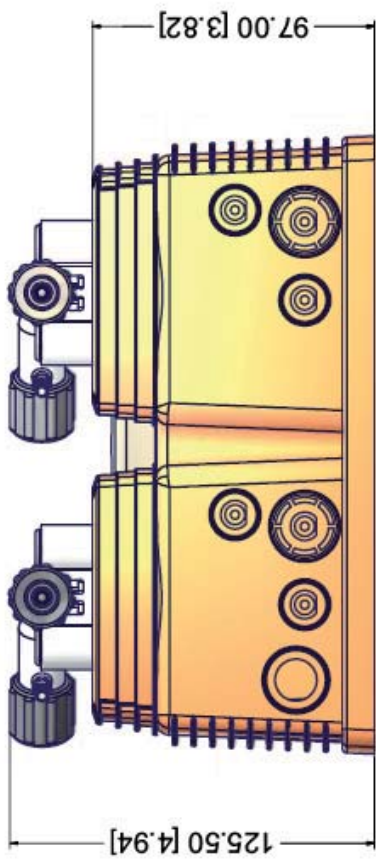
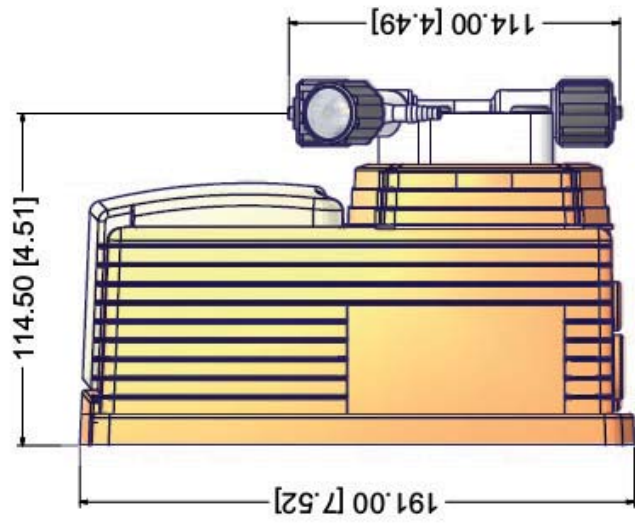

E Appendix. Chemical Compatibility Table

Solenoid driven metering pumps are widely used to dose chemical fluids and it is important that the most suitable material in contact with fluid is selected for each application. This compatibility table serves as a useful help in this respect. All the informations in this list are verified periodically and believed to be correct on the date of issuance. All the informations in this list are based on manufacturer's data and its own experience but since the resistance of any material depends by several factors this list is supplied only as an initial guide, in no way EMEC makes warranties of any matter respect to the informations provided in this list.

Chemical	Formula	Ceramic	PVDF	PP	PVC	SS 316	PMMA	Hastelloy	PTFE	FPM	EPDM	NBR	PE
Acetic Acid, Max 75%	CH ₃ COOH	2	1	1	1	1	3	1	1	3	1	3	1
Aluminium Sulphate	Al ₂ (SO ₄) ₃	1	1	1	1	1	1	1	1	1	1	1	1
Amines	R-NH ₂	1	2	1	3	1	-	1	1	3	3	1	1
Calcium Hydroxide (Lime Milk)(Slaked Lime)	Ca(OH) ₂	1	1	1	1	1	1	1	1	1	1	1	1
Calcium Hypochlorite (Chlorinated Lime)	Ca(OCl) ₂	1	1	1	1	3	1	1	1	1	1	3	1
Copper-II-Sulphate (Roman Vitriol)	CuSO ₄	1	1	1	1	1	1	1	1	1	1	1	1
Ferric Chloride	FeCl ₃	1	1	1	1	3	1	1	1	1	1	1	1
Hydrofluoric Acid 40%	HF	3	1	1	2	3	3	2	1	1	3	3	1
Hydrochloric Acid, Concentrate	HCl	1	1	1	1	3	1	1	1	1	3	3	1
Hydrogen Peroxide, 30% (Perydrol)	H ₂ O ₂	1	1	1	1	1	1	1	1	1	2	3	1
Nitric Acid, 65%	HNO ₃	1	1	2	3	2	3	1	1	1	3	3	2
Phosphoric Acid, 50% (Orthophosphoric Acid)	H ₃ PO ₄	1	1	1	1	2	1	1	1	1	1	3	1
Potassium Permanganate, 10%	KMnO ₄	1	1	1	1	1	1	1	1	1	1	3	1
Sodium Bisulphite	NaHSO ₃	1	1	1	1	2	1	1	1	1	1	1	1
Sodium Carbonate (Soda)	Na ₂ CO ₃	2	1	1	1	1	1	1	1	2	1	1	1
Sodium Hydroxide (Caustic Soda)	NaOH	2	1	1	1	1	1	1	1	2	1	2	1
Sodium Hypochlorite, 12.5%	NaOCl + NaCl	1	1	2	1	3	1	1	1	1	1	2	1
Sulphuric Acid, 85%	H ₂ SO ₄	1	1	1	1	2	3	1	1	1	3	3	1
Sulphuric Acid, 98.5%	H ₂ SO ₄	1	1	3	3	3	3	1	1	1	3	3	3

Resistance rating

Resistant	1
Fairly resistant	2
Not resistant	3

Materials

Polyvinylidene fluoride	PVDF	Pump Heads, valves, fitting, tubing
Polypropylene	PP	Pump Heads, valves, fitting, level floater
PVC	PVC	Pump Heads
Stainless steel	SS 316	Pump Heads, valves
Polymethyl Metacrilate (Acrylic)	PMMA	Pump Heads
Hastelloy C-276	Hastelloy	Injection valve spring
Polytetrafluoroethylene	PTFE	Diaphragm
Fluorocarbon (Viton® B)	FPM	Sealings
Ethylene propylene	EPDM	Sealings
Nitrile	NBR	Sealings
Polyethylene	PE	Tubing

F Appendix. Hoses resistance table

Hose features are very important for a reliable dosage. Every pump's model is made to work in the best way using selected hoses according to pump's capacity / model. Information reported here are intended for standard use only. For extended information ask to hose's manufacturer.

Suction / Delivery Hose			
4x6 mm PVC (transparent)	4x8 mm PE (opaque)	6x8 mm PE (opaque)	8x12 mm PVC (transparent)

Delivery Hose	Working Pressure				Breaking Pressure			
4x6 mm PE 230 (opaque)	20°C 12 bar	30°C 10.5 bar	40°C 8.5 bar	50°C 6.2 bar	20°C 36 bar	30°C 31.5 bar	40°C 25.5 bar	50°C 18.5 bar
4x8 mm PE 230 (opaque)	20°C 19 bar	30°C 15.7 bar	40°C 12 bar	50°C 7.5 bar	20°C 57 bar	30°C 47 bar	40°C 36 bar	50°C 22.5 bar
6x8 mm PE 230 (opaque)	20°C 8.6 bar	30°C 6.8 bar	40°C 4.8 bar	50°C 2.3 bar	20°C 26 bar	30°C 20.5 bar	40°C 14.5 bar	50°C 7 bar
8x12 mm PE 230 (opaque)	20°C 12 bar	30°C 10.5 bar	40°C 8.5 bar	50°C 6.2 bar	20°C 36 bar	30°C 31.5 bar	40°C 25.5 bar	50°C 18.5 bar
4x6 mm PVDF Flex 2800 (opaque)	20°C 40 bar	30°C 34 bar	40°C 30 bar	50°C 27 bar	60°C 24.8 bar	80°C 20 bar	90°C 10 bar	
6x8 mm PVDF Flex 2800 (opaque)	20°C 29 bar	30°C 25.5 bar	40°C 22 bar	50°C 20 bar	60°C 18 bar	80°C 14.5 bar	90°C 7.3 bar	
8X10 mm PVDF Flex 2800 (opaque)	20°C 18 bar	30°C 15.5 bar	40°C 13.5 bar	50°C 12.5 bar	60°C 11.2 bar	80°C 9 bar	90°C 4.5 bar	
1/4 PE 230 (opaque)	20°C 17.6 bar							
3/8 PE 230 (opaque)	20°C 10.6 bar							
1/2 PE 230 (opaque)	20°C 10.6 bar							



*When dismantling a pump please separate material types and send them according to local recycling disposal requirements.
We appreciate your efforts in supporting your local Recycle Environmental Program.
Working together we'll form an active union to assure the world's invaluable resources are conserved.*